

cp CIBERPAN®

THE
ABSOLUTE
ACCURACY

AUTOMATIC DOUGH DIVIDER MOD. 93



THE MAXIMUM PROFESSIONALITY AND SERIOUSNESS
WITH THE MOST ADVANCED TECHNOLOGY
NOISELESS AND EASY HANDLING

QUALITY
ENGINEERING
DESIGN

DIVISORA AUTOMÁTICA MOD. 93

Apta para dividir masa del 50 al 65% de agua (con teja heñidora) y de más del 65% de agua (sin teja heñidora). Precisión de peso $\pm 2\%$. Velocidad de producción de 1000 a 2400 piezas/hora. Sistema de engrase, consumo mínimo. Tolva de acero inoxidable cubierta con teflón antiadherente, capacidad básica 40kg, también en 80, 150 y 200kg. Cubiertas de acero inoxidable. Cuentapiezas con producción seleccionable. Cernedor de harina. Interruptor magnetotérmico.

AUTOMATIC DOUGH DIVIDER MOD. 93

Suitable for divide dough from 50 to 65% water (with rounder) and higher than 65% water (without rounder). Weight accuracy $\pm 2\%$. Production speed from 1000 to 2400 pieces/hour. Oiling system, minimum consumption. Stainless steel hopper covered with non-stick teflon, basic capacity 40kg, also in 80, 150 and 200kg. Stainless steel covering. Piececounter with selectable production. Flour sprinkler. Magnetic-thermal switch.

DIVISEUSE AUTOMATIQUE MOD. 93

Convenable pour pâte de 50 à 65% eau (avec rondeur) et plus haut que 65% eau (sans rondeur). Exactitude de pesée $\pm 2\%$. Vitesse de production de 1000 à 2400 morceaux/heure. Système huilant, consommation minimum. Tremie de acier inoxydable couvert de téflon antiadhésif, capacité 40kg de base, aussi en 80, 150 et 200kg. Revêtement de acier inoxydable. Compteur d'unités avec production sélectionnable. Farineur. Interrupteur aimanté-thermique.

SPEZZATRICE AUTOMATICA MOD. 93

Appropriata per dividere pasta da 50 a 65% d'acqua (con arrotondatrice) e più del 65% di acqua (senza arrotondatrice). Accuratezza di peso $\pm 2\%$. Velocità di produzione da 1000 a 2400 pezzi/ora. Sistema di lubrificazione, minimo consumo. Tramoggia di acciaio inossidabile copri con teflon antiaderente, capacità 40kg di base, anche di 80, 150 e 200kg. Copertura di acciaio inossidabile. Contapezzi con produzione selezionabile. Spruzzatore di farina. Interruttore magnetico-termale.

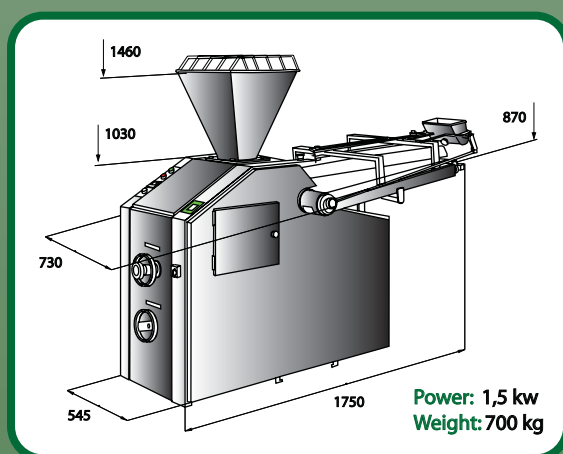

Piston Diam. (mm)	Minimum Weight (g)	Maximum Weight (g)
60	20	200
80	25	300
90	30	400
110	50	600
120	80	950
135	140	1300