

LOGIUDICE



Forno modulare
Modular Oven
Four modulaires
Horno modular

MODUS

LFM

ITA FORNO A PIANI MODULARE

Nello spazio ridotto e nella forma compatta del nuovo forno modulare elettrico Modus si racchiude tutta l'esperienza cinquantennale dell'azienda Logiudice Forni.

L'introduzione del nuovo modello di forno nella vasta gamma di prodotti Logiudice, nasce per soddisfare le esigenze funzionali di panifici, pasticcerie, pizzerie e punti caldi; Modus è uno strumento pratico, veloce e semplice da utilizzare.

Velocità di installazione, qualità dei materiali impiegati, misure compatte, diversificazione della produzione, isolamento termico sono alcuni dei requisiti che lo caratterizzano.

La configurazione del forno Modus si ottiene con un solo modulo e potrà essere ampliata sino a 4 blocchi sovrapposti (standard), opzionalmente fino a 5. Anche altri componenti come il supporto e la cappa di aspirazione, potranno essere aggiunti in seguito.

La camera di cottura è rivestita completamente in acciaio inox scotch-brite e isolata internamente da pannelli in lana di rocca; gli sportelli sono in vetro temperato o acciaio inox.

Il piano è in cemento refrattario o lamiera bugnata e le resistenze elettriche sono allineate a vista nella parte superiore della camera e sotto il piano di cottura.

Ciascun modulo è indipendente dagli altri; ognuno dispone di un controllo della temperatura separato tra cielo e platea, tale da poter calibrare i parametri in base alle varie esigenze; questo sistema favorisce una cottura omogenea e diversa per ogni prodotto. Il pannello comandi è disponibile nella versione digitale con programmi (standard) oppure touch-screen. L'altezza utile interna della camera è da 18 cm o 24 cm.

Vaporiera (optional): nel retro della camera di cottura è predisposto lo spazio per installare una vaporiera compatta ma di elevata prestazione, essa favorisce ottimi risultati alle cotture, rendendo il prodotto morbido all'interno e croccante e dorato all'esterno.

In opzione, all'interno della cappa di aspirazione, è presente un sistema di filtraggio dei vapori che elimina la condensa.



ENG MODULAR DECK OVEN

All the Logiudice Forni company's fifty years of experience are contained within the reduced space and compact form of the new Modus modular electric oven.

The new oven model was introduced among the wide range of Logiudice products in order to meet the functional needs of bakeries, pastry shops, pizzerias, and hot spots alike; the Modus is fast, practical, and easy to use.

Some of its most salient features include quick installation, high-quality materials, compact size, product diversification, and excellent thermal insulation.

The configuration of the Modus oven is obtained with a single module, and can be extended to include up to 4 stacked decks (standard), or optionally up to 5. Additional components, like the support and the extractor hood, can also be added at a later time.

The baking chamber is entirely clad in scotch-brite stainless steel and is internally insulated by rock wool panels; the doors are made of tempered glass or stainless steel. The deck is made from refractory cement or textured sheet metal, and the visible heating elements are aligned in the upper portion of the chamber and under the deck.

Each module is independent of the others; each has a separate top and bottom temperature control, thus allowing the parameters to be set based on the user's specific requirements; this system ensures uniform and diverse baking conditions for every type of product. The control panel is available in a digital version with programs (standard) or touch-screen display. The inner chamber has a useful height of 18 cm or 24 cm.

Steamer (optional): the back of the baking chamber features a space for installing a compact yet high performance steamer, which provides for optimal baking results by making the product soft on the inside, and golden and crispy on the outside.

The extraction hood can even be equipped with a steam filtration system in order to eliminate condensation.



MODUS

LFM

FRA FOUR À SOLE MODULAIRE

Les cinquante ans d'expérience de Logiudice Forni émergent dans l'espace réduit et la forme compacte du nouveau four modulaire électrique Modus.

Ce nouveau four a été introduit dans la vaste gamme de produits pour satisfaire les besoins des boulangeries, pâtisseries, pizzérias et points chauds; Modus est un four pratique, rapide et simple à utiliser.

L'installation rapide, la qualité des matériaux, le format compact, la diversification de la production et l'isolation thermique sont quelques-unes des exigences qui le caractérisent.

La configuration du four Modus s'obtient avec un seul module et pourra être étendue jusqu'à 4 blocs superposés (version standard), et éventuellement 5 blocs en version optionnelle. D'autres composants comme le support et la hotte aspirante pourront être également ajoutés par la suite.

La chambre de cuisson est entièrement en acier inox scotch-brite, isolée avec des panneaux en laine de verre; les portes sont en verre trempé ou en acier inox; la sole est en ciment réfractaire ou en tôle gaufrée et les résistances électriques sont alignées et visibles dans la partie supérieure de la chambre et au dessous de la dalle de cuisson.

Chaque module est indépendant des autres; ils disposent chacun d'un contrôle de la température séparé entre la sole et la voûte, afin de pouvoir régler les paramètres en fonction des différents besoins; ce système favorise une cuisson homogène et différente pour chaque produit. Le panneau de commandes est disponible dans la version digitale avec programmes (standard) ou tactile.

La hauteur utile de la chambre est de 18 cm ou de 24 cm.

Appareils à buée (en option): derrière la chambre de cuisson un espace est prédisposé pour installer un appareil à buée compact mais très performant; il offre d'excellents résultats de cuisson, en rendant le produit moelleux à l'intérieur et croquant et doré à l'extérieur. En option, à l'intérieur de la hotte d'aspiration se trouve un système de filtrage des vapeurs qui élimine la condensation.



ESP HORNO DE PISOS MODULAR

En el espacio reducido y la forma compacta del nuevo horno modular eléctrico Modus se encierra toda la experiencia de más de cincuenta años en el sector de la panadería de Logiudice Forni.

La introducción de este nuevo modelo de horno en la amplia gama de productos Logiudice, nace para satisfacer las exigencias funcionales de panaderías, pastelerías, pizzerías y puntos calientes; Modus es un instrumento práctico, rápido y fácil de utilizar.

Velocidad de instalación, calidad de los materiales empleados, medidas compactas, diversificación de la producción, aislamiento térmico son sólo algunos de los requisitos que lo caracterizan.

La configuración del horno Modus se obtiene con un solo módulo y podrá ampliarse hasta alcanzar 4 cámaras sobrepuestas (estándar), opcionalmente, hasta 5. Posteriormente podrán añadirse también otros componentes como el soporte y la campana de aspiración.

La cámara de cocción está recubierta totalmente en acero inoxidable scotch-brite y aislada internamente por paneles de lana de roca; las puertas son de vidrio templado o de acero inox.

El suelo es de cemento refractario ó de chapa estriada y las resistencias eléctricas están alineadas a vista en la parte superior de la cámara y en la parte inferior del piso refractario.

Cada módulo es independiente de los otros; cada uno dispone de un control separado de la temperatura entre el cielo y la platea, tal de poder calibrar los parámetros según las diferentes exigencias; este sistema favorece una cocción homogénea y diferente para cada producto. El panel de mandos está disponible en la versión digital Orion con programas (standard) ó Touch screen.

La altura útil de la cámara interna es de 18 cm y de 24 cm.

Vaporera (opcional): en la parte posterior de la cámara de cocción hay un espacio predispuesto donde se puede instalar una vaporera compacta pero de elevadas prestaciones. Ésta permite realizar diferentes cocciones con óptimos resultados, permitiendo que el producto sea blando en su interior y crocante y dorado en su exterior.

Como opción, dentro de la campana de aspiración, está presente un sistema de filtración de los vapores que elimina la condensación.



MODUS

Modello Model Modèle Modelo	Teglie Trays Plaques Bandejas	Dim. teglie Trays dim. Dim. plaques Dim. bandejas	Dimensioni camera Decks dimensions Dimensions Chambres Dimensiones cámaras			Dimensioni esterne Outside dimensions Dimensions extérieures Dimensiones externas			Potenza Power Puissance Potencia	Peso Weight Poids Peso
			A	B	H1	C	D	H2		
			cm	cm	cm	cm	cm	cm		

LFM 2T 4060

LFM-2T-4060	2	40X60	62	85	18/24	93	128	31/37	5.5	170
LFM-2T-4060-V	2	40X60	62	85	18/24	93	128	31/37	8	170
TOP	---	---	---	---	---	93	128	7	---	54
STAND	10/14	40X60	---	---	---	93	112	67/87*	---	63/73
CAPPA	---	---	---	---	---	93	132	26	0.2	24
LFM-2T-4060	2	40X60	82	70	18/24	113	113	31/37	6	190
LFM-2T-4060-V	2	40X60	82	70	18/24	113	113	31/37	8.5	190
TOP	---	---	---	---	---	113	113	7	---	59
STAND	10/14	40X60	---	---	---	113	97	67/87*	---	68/80
CAPPA	---	---	---	---	---	113	117	26	0.2	26

LFM 3T 4060

LFM-3T-4060	3	40X60	124	70	18/24	155	113	31/37	9	247
LFM-3T-4060-V	3	40X60	124	70	18/24	155	113	31/37	11.5	247
TOP	---	---	---	---	---	155	113	7	---	80
STAND	20/28	40X60	---	---	---	155	117	67/87*	---	73/84
CAPPA	---	---	---	---	---	155	117	26	0.2	31

LFM 4T 4060

LFM-4T-4060	4	40X60	82	125	18/24	113	168	31/37	10.5	330
LFM-4T-4060-V	4	40X60	82	125	18/24	113	168	31/37	13	330
TOP	---	---	---	---	---	113	168	7	---	87
STAND	20/28	40X60	---	---	---	113	152	67/87*	---	89/106
CAPPA	---	---	---	---	---	113	172	26	0.2	29
LFM-4T-4060	4	40X60	124	85	18/24	155	128	31/37	10.5	300
LFM-4T-4060-V	4	40X60	124	85	18/24	155	128	31/37	13	300
TOP	---	---	---	---	---	155	128	7	---	91
STAND	20/28	40X60	---	---	---	155	112	67/87*	---	78/92
CAPPA	---	---	---	---	---	155	132	26	0.2	31

LFM 6T 4060

LFM-6T-4060	6	40X60	124	125	18/24	155	168	31/37	16	450
LFM-6T-4060-V	6	40X60	124	125	18/24	155	168	31/37	18.5	450
TOP	---	---	---	---	---	155	168	7	---	129
STAND	30/42	40X60	---	---	---	155	152	67/87*	---	96/112
CAPPA	---	---	---	---	---	155	172	26	0.2	33

TOP = Divisione tra piani - Top and base insulation **STAND** = Supporto - Stand - Support - Soporte **CAPPA** = Cappa - Hood - Hotte - Campana
 * h ruote (Wheels - Roues - Ruedas)) 16 cm

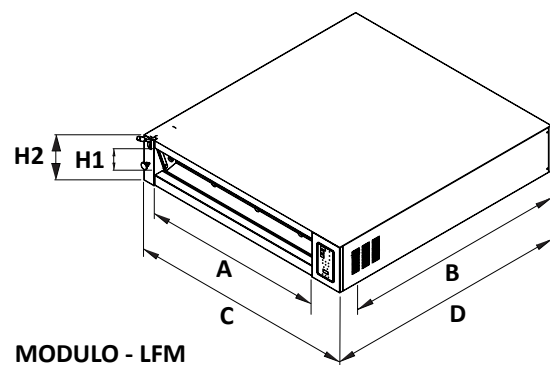
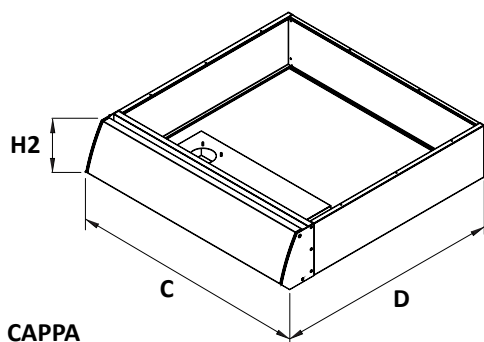

MODUS

Modello Model Modèle Modelo	Teglie Trays Plaques Bandejas	Dim. teglie Trays dim. Dim. plaques Dim. bandejas	Dimensioni camere Decks dimensions Dimensions Chambres Dimensiones cámaras			Dimensioni esterne Outside dimensions Dimensions extérieures Dimensiones externas			Potenza Power Puissance Potencia	Peso Weight Poids Peso
			A cm	B cm	H1 cm	C cm	D cm	H2 cm		
	N°	cm							Kw	Kg

LFM 2T 4666 - 4676

LFM-2T-4666-4676	2	46X76 - 46X66	82	105	18 / 24	113	148	31	9	280
LFM-2T-4666-4676-V	2	46X76 - 46X66	82	105	18 / 24	113	148	31	11.5	280
TOP	---	---	---	---	---	113	148	7	---	61
STAND	10/14	46X76 - 46X66	---	---	---	113	132	67/87*	---	82/96
CAPPA	---	---	---	---	---	113	152	26	0.2	27
LFM-2T-4666-4676	2	46X76 - 46X66	102	85	18/24	133	128	31/37	8.5	250
LFM-2T-4666-4676-V	2	46X76 - 46X66	102	85	18/24	133	128	31/37	11	250
TOP	---	---	---	---	---	133	128	7	---	79
STAND	10/14	46X76 - 46X66	---	---	---	133	112	67/87*	---	76/89
CAPPA	---	---	---	---	---	133	132	26	0.2	29

LFM 3T 4666

LFM-3T-4666	3	46X66	143	70	18/24	174	113	31/37	10	320
LFM-3T-4666-V	3	46X66	143	70	18/24	174	113	31/37	12.5	320
TOP	---	---	---	---	---	174	113	7	---	90
STAND	20/28	46x66	---	---	---	174	97	67/87*	---	75/86
CAPPA	---	---	---	---	---	174	117	26	0.2	33

LFM 4T 4666

LFM-4T-4666	4	46X66	102	140	18/24	133	183	31/37	16	390
LFM-4T-4666-V	4	46X66	102	140	18/24	133	183	31/37	18.5	390
TOP	---	---	---	---	---	133	183	7	---	110
STAND	20/28	46x66	---	---	---	133	167	67/87*	---	98/116
CAPPA	---	---	---	---	---	133	187	26	0.2	32

LFM 6T 4666

LFM-6T-4666	6	46X66	143	140	18/24	174	183	31/37	18.5	500
LFM-6T-4666-V	6	46X66	143	140	18/24	174	183	31/37	21	500
TOP	---	---	---	---	---	174	183	7	---	140
STAND	30/42	46x66	---	---	---	174	167	67/87*	---	105/123
CAPPA	---	---	---	---	---	174	187	26	0.2	36

Optional

Pannello comandi touch screen (7") - Touch screen control panel (7") - Tableau de commande écran tactile (7")
Panel de comandos touch screen (7")

Vaporiera - Steamer - Générateur de vapeur - Vaporera

Piano cottura in lamiera bugnata - Deck made of textured sheet metal - Sole en tôle gaufrée - Suelo de chapa estriada

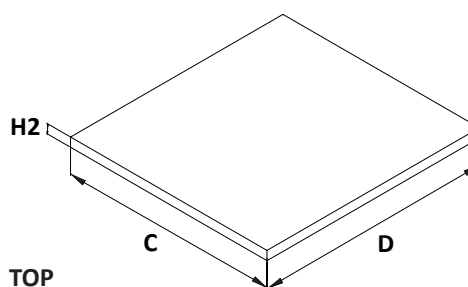
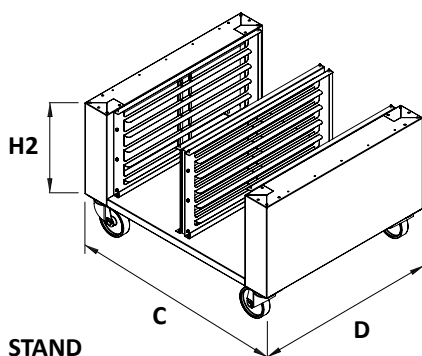



Logiudice Forni srl
Via Macia, 14
37040 Arcole - Verona
Italy

Tel. +39 045 618 0 126
Tel. +39 045 766 50 56

Fax +39 045 766 56 03

info@logiudiceforni.com
www.logiudiceforni.com



MODUS

zienda si riserva il diritto di apportare eventuali modifiche nell'ottica di un continuo miglioramento dei propri prodotti.
The Manufacture reserves the right to make any change to the product with the purpose of improving its quality.