

LOGIUDICE FORNI

technologies by tradition



Forno rotativo - 15 teglie
Rack oven - 15 trays
Fours rotatif - 15 plaques
Horno rotativo - 15 bandejas

www.logiudiceforni.com

ROTOR FOX - 15 T

Modello Model Modèle Modelo	Teglie Trays Plaques Bandejas	Dim. teglie Trays dim. Dim. Plaques Dim. Bandejas	Spazio teglie Tray Clearance Distance entre plaques Separacion entre Pisos	Dimensioni esterne Out side dimensions Dimensions extérieures Dimensiones externas					Peso Weight Poids Peso
				A cm	B cm	C cm	H 1 cm	H 2 cm	
FOX	N°	cm	cm						
LFRC - 15T 4060	15	40x60	9	100	125	153	200	212	715
LFRCE - 15T 4060									
LFRC - 15T 5070	15	46x66 45X75 50X70 40X80	9	110	140	168	200	221	735
LFRCE - 15T 5070									

Modello Model Modèle Modelo	Potenzialità termica Thermic power Puissance thermique Potencia tèrmica			Potenza elettrica Electric power Puissance électrique Potencia eléctrica
	Kcal/h	Kw	Btu/h	Kw
FOX				
LFRC - 15T 4060	28.000	34	112.000	---
LFRCE - 15T 4060	---	---	---	27
LFRC - 15T 5070	35.000	42	140.000	---
LFRCE - 15T 5070	---	---	---	27

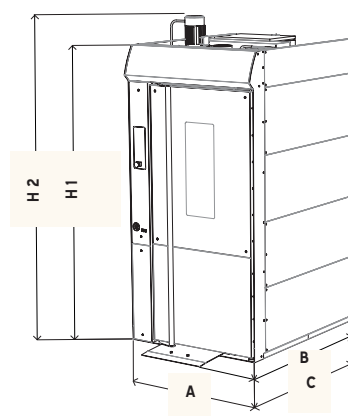

FRA FOURS ROTATIF - 15 PLAQUES

Fours conseillés pour la cuisson de tout type de pain et de produit pour la pâtisserie.

- Four entièrement en acier inox intérieur et extérieur.
- Système de rotation par crochet supérieur.
- Fonctionnement à gaz, gazoil et électrique.
- Tableau digital avec démarrage automatique.
- Double appareil à buée à cascade.
- Vanne extraction de buée manuelle.
- Porte avec double vitrage et double système de fermeture.
- Eclairage de la chambre effectuée par deux lampes halogènes.
- Hotte de aspiration inclus.

EN OPTION:

- Tableau digital avec 99 programmes et gestion des différentes phases de cuisson.
- Ouverture de la porte réversible.

ESP HORNO ROTATIVO - 15 BANDEJAS

Hornos recomendados para la cocción de todos los tipos de panes y productos de pastelería.

- Horno completamente en acero inoxidable.
- Sistema de rotación con gancho superior.
- Funcionamiento a gas, gasóleo, eléctrico.
- Panel de control digital con encendido automático.
- Vaporera doble con sistema a cascada.
- Válvula extracción de vapores manual.
- Puerta con doble cristal y sistema de doble bloqueo.
- Iluminación cámara de cocción con dos lámparas halógenas.
- Aspirador de vapores y campana incluidos.

OPCIONAL:

- Panel digital con 99 programas con gestión de la cocción en 9 fases.
- Puerta reversible.

FORNO CON CARRELLO ROTATIVO - 15 TEGLIE

Forni consigliati per la cottura di qualsiasi tipo di pane e prodotto per la pasticceria.

- Forno costruito interamente in acciaio inox.
- Sistema di rotazione con gancio superiore.
- Funzionamento a gas, gasolio ed elettrico.
- Pannello digitale con accensione automatica.
- Doppia vaporiera a cascata.
- Valvola manuale estrazione vapori.
- Porta con doppio vetro e doppio sistema di chiusura.
- Illuminazione camera con due lampade alogene.
- Cappa di aspirazione inclusi.

OPTIONAL:

- Pannello digitale 99 programmi con gestione fasi di cottura.
- Apertura porta reversibile.



RACK OVEN - 15 TRAYS

Ovens recommended for baking any type of bread or pastry products.

- Heavy duty stainless steel interior and exterior.
- Rack rotation system with upper hook.
- Gas, gasoil or electric
- Digital control panel with automatic weekly start up.
- Double built-in steam generator, water drop system.
- Manual steam exhaust valve.
- Double glaze door with double-locking system.
- Double internal light.
- Canopy included.

OPTIONAL:

- Digital control with storage for up to 99 programmed recipes.
- Reversible door opening.

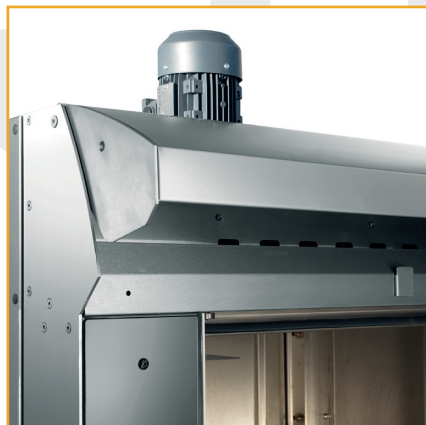

LOGIUDICE



Logiudice Forni SRL
Via Madonna Pellegrina, 29
37047, San Bonifacio
Verona - Italy

Tel. +39 045 618 0 126
Fax +39 0442 490 444

info@logiudiceforni.com
www.logiudiceforni.com



FOX 15

graphic design: eleonora@logiudiceforni.com
photo: www.andreacracco.it

L'azienda si riserva il diritto di apportare eventuali modifiche nell'ottica di un continuo miglioramento dei propri prodotti.
The Manufacture reserves the right to make any change to the products with the purpose of improving its quality.