

PLANET MİKSER C LINE SERİSİ
Teknik Tablo

Model	Kapasite	Devir hızı	Elektrik gücü	Ağırlık	Parçalar Çırpma teli Spiral kol Spatül	Dış ölçüler			Asansör yapısı	Kit Grubu 1 Kazan 1 Çırpıcı tel 1 Spiral kol 1 Spatül	İnverter	Kontrol paneli	Paslanmaz yapı
						A cm	B cm	H cm					
	Lt	RPM	Kw	Kg									
C - LINE 10									Manuel				
C - LINE 20	20	100-415	0,75	105	Standart	45	66	82	Manuel	10	Var	24 V	Opsiyonel
C - LINE 30	30	100-415	0,75	115	Standart	45	66	122	Manuel	-	var	24 V	Opsiyonel
C - LINE 40	40	100-415	0,75	120	Standart	45	66	122	Manuel	10 (Opsiyonel)	Var	24 V	Opsiyonel
C - LINE 50	50	100-415	2,2	200	Standart	59	87	140	Manuel	20 (Opsiyonel)	Var	24 V	Opsiyonel
C - LINE 60	60	100-415	3,0	240	Standart	67	87	140	Manuel	40 (Opsiyonel)	Var	24 V	Opsiyonel

C- LİNE Ölçüler

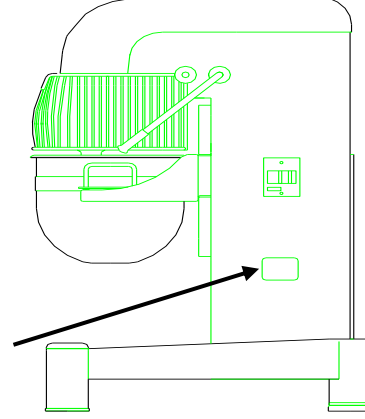
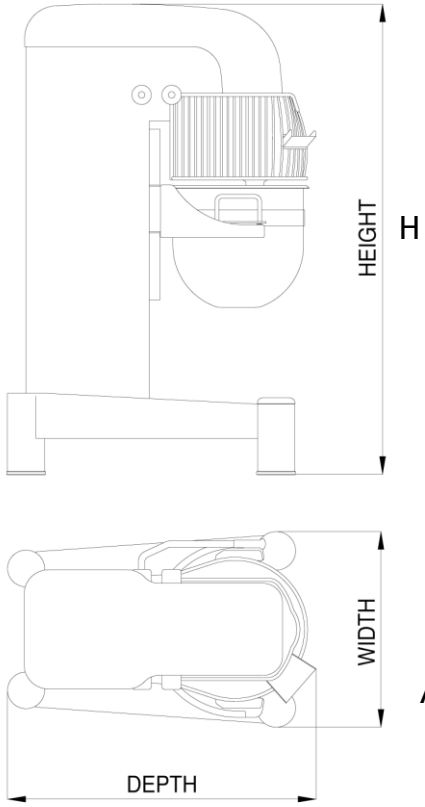

HIZ VE ZAMAN KONTROL ÖZELLİKLERİNE SAHİP KONTROL PANELİ SEMBOLLERİ



3 HIZ ÖZELLİĞİNE SAHİP KONTROL PANELİ SEMBOLLERİ

B